

DUCT SMOKE DETECTOR

Early Smoke Detection in HVAC Systems

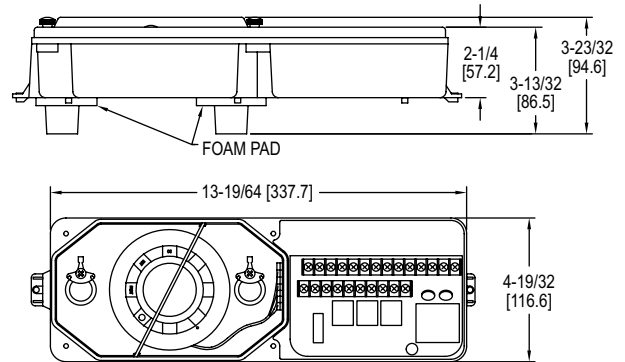

The **Series SL-2000 Duct Smoke Detector** is crucial for early detection of smoke and products of combustion present within HVAC ductwork. This series can be utilized in many different types of applications including commercial, industrial, and residential. The unit is designed to not only alarm when smoke is detected, but will also utilize relays to disable fans and blowers. The series comes complete with technician friendly "No-Tools Required" features to make installation and servicing simple and efficient.

BENEFITS/FEATURES

- Versatile installation applications with velocities up to 4000 FPM
- Easy performance verification with the built-in smoke and magnet test ports and clear cover to view status LED
- Simple installation with no tools required to load/remove sampling tubes

APPLICATIONS

- Early smoke detection in ductwork
- Commercial/industrial/residential HVAC
- BAS automation

SPECIFICATIONS

Sensor Type: Photoelectric or Ionization.
Air Velocity Range: 100 to 4000 FPM.
Ambient Temperature: SL-2000-P: 32 to 140°F (0 to 60°C).
Humidity Limits: 85 ±5 % RH (@32 ±2°C; 86 ±3.6°F) Non-condensing/non-freezing.
Power Requirements: Standby: 230 VAC (12 mA), 115 VAC (22 mA), 24 VAC (55 mA), or 24 VDC (14 mA); Alarm: 230 VAC (18 mA), 115 VAC (32 mA), 24 VAC (190 mA), or 24 VDC (68 mA).
Electrical Rating: Alarm contacts: 2 sets form "C" rated at 10 A resistive @ 115 VAC and 1 set form "A" rated at 2 A; Trouble contacts: 1 set form "C" rated at 10 A @ 115 VAC.
Electrical Connections: Screw terminals.
Enclosure: Grey plastic backbox, clear plastic cover (Makrolon® 94 V-0).
Enclosure Rating: SL-2000: NEMA 1; WP-2000: NEMA 3R.
Weight: 2.5 lb.
Approvals: cULus (UL 268A) file # S2829, CSFM listed (3240-1004:105), MEA accepted (73-92-E; VOL. 27).

MODEL CHART	
Model	Sensor Type
SL-2000-P	Conventional, 4-wire, universal voltage, photoelectric duct smoke detector

ACCESSORIES	
Model	Sensor Type
55000-328APO	Photoelectric replacement sensor for SL-2000-P
FAST TUBE	Sectional, polycarbonate sampling tube, bag of (3) 24" tubes
TG-2500	Test gas for SL-2000 models
WP-2000	Weatherproof enclosure for SL-2000 models