

Signet 2100 Turbine Flow Sensor

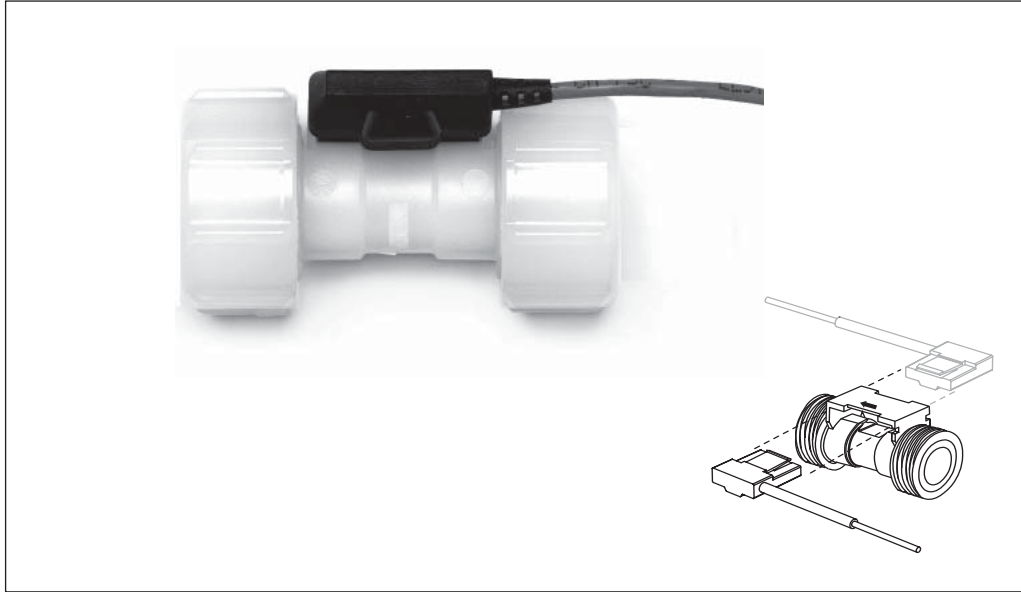









Description

Engineered specifically for small pipe diameter applications, the Signet 2100 Turbine Flow Sensor provides accurate readings in two flow ranges: 0.3 to 3.8 lpm and 3 to 38 lpm (0.1 to 1 gpm and 0.8 to 10 gpm).

The injection-molded PVDF body and ceramic bearings provide excellent chemical compatibility and long service in dosing and batching applications. Union piping and tubing

connections along with removable NEMA 4X electronics allow for easy assembly and field replaceability. The 2100 can be used with DN8 (1/4 in.), DN10 (3/8 in.), DN15 (0.5 in.) tubing, or DN15 (0.5 in.) piping for simple installation. End connections are available in PVDF for hose barbs, flare ends, fusion socket or IR/butt fusion, and in PVC for socket or NPT thread.

System Overview

<p>Panel Mount Signet Flow Instrument (sold separately) 8550 5075 8900 5500 5600</p> 	<p>Pipe, Tank, Wall Mount Signet Flow Instrument (sold separately) 8550</p>  <p>Signet Universal Adapter Kit (3-8050) (sold separately)</p> 
<p>Signet 2100 Flow Sensor</p> 	<p>Signet 2100 Flow Sensor</p> 
<p>End Connector options</p> <div style="display: flex; justify-content: space-around;"> <div data-bbox="138 1785 365 1911"> <p>Fusion, threaded or solvent socket connectors for DN15 (1/2 in.) pipe</p>  </div> <div data-bbox="381 1785 609 1911"> <p>Hose barb connectors for DN8, DN10, or DN15 (1/4 in., 3/8 in. or 1/2 in.) flexible tubing</p>  </div> <div data-bbox="625 1785 876 1911"> <p>Flare end connectors for DN8, DN10, or DN15 (1/4 in., 3/8 in., or 1/2 in.) rigid tubing.</p>  </div> </div>	

Features

- Flow rate range of 0.38 to 38 lpm (0.10 to 10 U.S. gpm)
- Unaffected by mounting angles
- Non-magnetic turbine
- Union ends for various connector types
- End connector kits for rigid or flexible tubing or DN15 (0.5 in.) pipe
- PVDF & ceramic wetted parts provide superior chemical compatibility
- For use with both clear and opaque fluids
- Small and compact design
- 4.6m (15 ft.) cable
- Features removable electronics that installs from either side of the sensor

- Sensor mounts at any angle

Application

- Chemical Addition
- Textile dyeing
- High-purity Chemical Dispensing
- Water Addition
- Fertilization
- Dosing
- Pump Protection
- Not suitable for gases





Dimensions

L = overall length

- All sockets: 102 mm (4 in.)
- Butt fusion/IR: 170 mm (6.7 in.)
- All flare ends: 47 mm (1.85 in.)
- 1/4 in. Barb: 124 mm (4.9 in.)
- 3/8 in. Barb: 127 mm (5 in.)
- 1/2 in. Barb: 132 mm (5.2 in.)

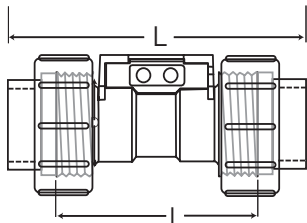

l = 64 mm (2.5 in.) Electronics module

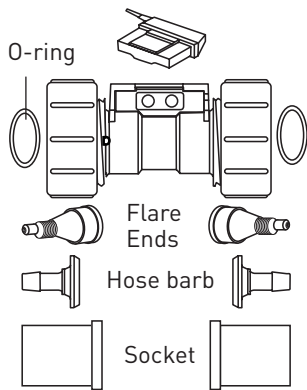

Application Tips:

- All socket and hose barb connector kits are sold individually. Two kits are required for each sensor.
- Flare end connector kits are sold in package of two.
- Mount at any angle.
- Terminal block recommended if standard cable is extended to maximum 300 m (1000 ft.)

Please refer to **Wiring, Installation, and Accessories** sections for more information.

Specifications

General

- Flow range:
 - L = 0.38 to 3.8 lpm (0.10 to 1 U.S. gpm)
 - H = 3 to 38 lpm (0.8 to 10 U.S. gpm)
 - H (w/flare) = 3 to 27 lpm (0.8 to 7 U.S. gpm)
- Linearity: ±3% of reading
- Repeatability: ±0.5% of reading
- Pipe size range: DN15 (1/2 in.)
- Hose size: DN8 (1/4 in.), DN10 (3/8 in.), DN15 (1/2 in.)

Wetted Materials

- Sensor body/rotor: PVDF
- Shaft/bearings: Ceramic
- O-rings: -1 = FPM, -2 = EPDM
- Electronics:
 - PBT (polybutylene terephthalate)
 - EVA (ethylene vinyl acetate)

Electrical

- Power: 5 to 24 VDC @ 1.5 mA max.
- Reverse polarity protected

Electrical (continued)

- Output: Open collector, sinking, max 30 mA
- Cable type: PVC jacketed, 2 conductor twisted pair with shield (22 AWG)
- Cable length: 4.6 m (15 ft.)
- Max. Pressure/Temperature Rating**
 - 16 bar @ 20°C, 9.3 bar @ 70 °C
 - (232 psi @ 68°F, 130 psi @ 158°F)
- Operating temperature: -20° to 70°C (-4° to 158°F)
- Storage temperature: -15° to 80°C (5° to 176°F)
- Relative humidity: 0 to 95%, non-condensing
- See Temperature and Pressure graphs/
- Shipping Weight:** 0.15 kg (0.33 lbs)
- Standards and Approvals**
 - CE
 - Manufactured under ISO 9001:2000 for Quality and ISO 14001:2004 for Environmental Management

Ordering Information

Sensor Part Number	
3-2100	Turbine flow sensor, PVDF body and rotor, for use with various end-connectors
	O-ring material - Choose one
-1	FPM
-2	EPDM
	Flow range
L	low, 0.38 to 3.8 lpm (0.10 to 1 gpm)
H	high, 3 to 38 lpm (0.8 to 10 gpm) except if used with flare fitting
H	high, 3 to 27 lpm (0.8 to 7 gpm) when used with flare fitting
3-2100	-1 L Example Part Number
*Note: To install this flow sensor, end fittings must be installed on both ends of the sensor. See selection below	
Fitting Part Number	
3-2100	End fitting for Model 2100 sensor
	Type of end fitting
-31	Hose barb connector kit, PVDF, 1/2 inch (1-hose barb and 1-ring nut)
-32	Hose barb connector kit, PVDF, 3/8 inch (1-hose barb and 1-ring nut)
-33	Hose barb connector kit, PVDF, 1/4 inch (1-hose barb and 1-ring nut)
-34	Fusion socket connector, PVDF, DN 15 1/2 inch (1-fusion socket and 1 ring nut)
-35	Butt Fusion/IR connector kit, PVDF, DN 15 1/2inch (1-IR socket and 1 ring nut)
-36	Metric socket connector kit, PVC, 1/2 inch (1-solvent socket and 1 ring nut)
-37	SCH 80 socket connector kit, PVC, 1/2 inch (1-solvent socket and 1 ring nut)
-38	NPT thread socket connector kit, PVC, 1/2 inch (1-threaded socket and 1 ring nut)
-40	Flare end, 1/2 inch (2 flare ends, 2 flare nuts, and 2 ring nuts)
-41	Flare end, 3/8 inch (2 flare ends, 2 flare nuts, and 2 ring nuts)
-42	Flare end, 1/4 inch (2 flare ends, 2 flare nuts, and 2 ring nuts)
3-2100	-33 Example Part Number

Mfr. Part No.	Code	Mfr. Part No.	Code
3-2100-1L	159 000 001	3-2100-35	159 000 009
3-2100-2L	159 000 003	3-2100-36	159 000 010
3-2100-1H	159 000 002	3-2100-37	159 000 011
3-2100-2H	159 000 004	3-2100-38	159 000 012
3-2100-31	159 000 005	3-2100-40	159 000 633
3-2100-32	159 000 006	3-2100-41	159 000 634
3-2100-33	159 000 007	3-2100-42	159 000 635
3-2100-34	159 000 008		

Accessories and Replacement Parts

Mfr. Part No.	Code	Description
1220-0018	159 000 019	O-rings FPM (2 required per sensor)
1224-0018	159 000 020	O-rings EPDM (2 required per sensor)
3-2100.390-1L	159 000 015	Turbine Lo Flow with FPM O-rings (replacement body)
3-2100.390-1H	159 000 016	Turbine Hi Flow with FPM O-rings (replacement body)
3-2100.390-2L	159 000 017	Turbine Lo Flow with EPDM O-rings (replacement body)
3-2100.390-2H	159 000 018	Turbine Hi Flow with EPDM O-rings (replacement body)
3-2100.390	159 000 014	Electronics Module with 15 ft. (4.6 m) cable